

## T-spojka T

### připojení EO 24°

Těleso šroubení ocel a mosaz (S3)

řada LL 4-10 mm D1

řada L 6+8 mm D1

řada S 6 mm D1

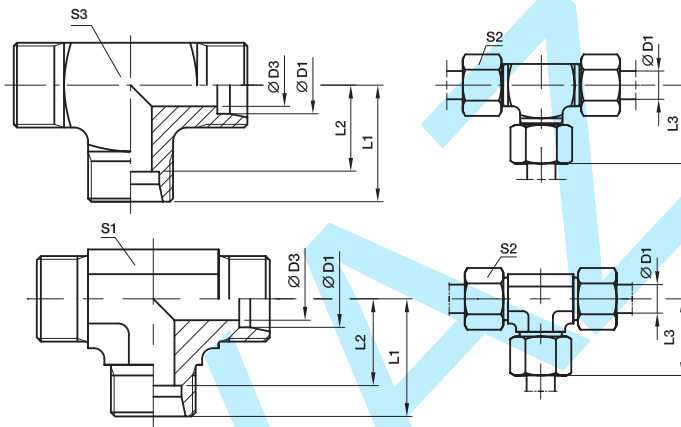

Konstr. řada	D1	D3	L1	L2	L3	S1	S2	S3	Hmotnost g/1 ks	Objednáací kód*	PN (bar) <sup>1)</sup>				
											CF	A3C	71	MS	
LL <sup>2)</sup>	4	3,0	15	11,0	21	9	10	9	19	T04LL	100	100	100	63	
	6	4,5	15	9,5	21	9	12	11	20	T06LL	100	100	100	63	
	8	6,0	17	11,5	23	12	14	12	27	T08LL	100	100	100	63	
	10	8,0	18	12,5	24	12	17	14	39	T10LL	100	100	100	63	
	12	10,0	21	15,0	27	14	19		45	T12LL	100	100	100	63	
L <sup>3)</sup>	6	4,0	19	12,0	27	12	14	12	37	T06L	500	315	315	200	
	8	6,0	21	14,0	29	12	17	14	53	T08L	500	315	315	200	
	10	8,0	22	15,0	30	14	19		48	T10L	500	315	315	200	
	12	10,0	24	17,0	32	17	22		65	T12L	400	315	315	200	
	15	12,0	28	21,0	36	19	27		106	T15L	400	315	315	200	
	18	15,0	31	23,5	40	24	32		179	T18L	400	315	315	200	
	22	19,0	35	27,5	44	27	36		225	T22L	250	160	160	100	
	28	24,0	38	30,5	47	36	41		396	T28L	250	160	160	100	
	35	30,0	45	34,5	56	41	50		567	T35L	250	160	160	100	
	42	36,0	51	40,0	63	50	60		905	T42L	250	160	160	100	
	S <sup>4)</sup>	6	4,0	23	16,0	31	12	17	14	68	T06S	800	630	630	400
		8	5,0	24	17,0	32	14	19		70	T08S	800	630	630	400
		10	7,0	25	17,5	34	17	22		91	T10S	800	630	630	400
		12	8,0	29	21,5	38	17	24		117	T12S	630	630	630	400
14		10,0	30	22,0	40	19	27		136	T14S	630	630	630	400	
16		12,0	33	24,5	43	24	30		202	T16S	630	400	400	250	
20		16,0	37	26,5	48	27	36		289	T20S	420	400	400	250	
25		20,0	42	30,0	54	36	46		545	T25S	420	400	400	250	
30		25,0	49	35,5	62	41	50		758	T30S	420	400	400	250	
38		32,0	57	41,0	72	50	60		1264	T38S	420	315	315	200	

<sup>1)</sup> Je-li hodnota tlaku uvedena, zboží lze dodat

<sup>2)</sup> LL = velmi lehká konstrukční řada

<sup>3)</sup> L = lehká konstrukční řada

<sup>4)</sup> S = těžká konstrukční řada

$$PN \text{ (bar)} = \frac{PN \text{ (MPa)}}{10}$$

**Dodávka bez matice a zářezného kroužku. Pokyny pro objednávku kompletního šroubení viz strana H7.**

\*Doplňte objednáací kód zkratkou označení pro žádaný materiál.

Doplnění objednáacího kódu		
Materiál	Zkratka označení povrchové ochrany materiálu	Příklad
Pozinkovaná ocel bez chromu <sup>6)</sup>	CFX	T165CFX
Pozinkovaná ocel	A3CX	T165A3CX
Nerezová ocel	71X	T16571X
Mosaz	MSX	T165MSX